

Nuclear Science and Technology Division (94)

## **INTEGRATED KENO MONTE CARLO TRANSPORT FOR 3-D DEPLETION WITH SCALE**

**Stephen M. Bowman, Mark D. DeHart, and Lester M. Petrie**

Oak Ridge National Laboratory,\*  
P.O. Box 2008,  
Oak Ridge, TN 37831-6170  
[bowmansm@ornl.gov](mailto:bowmansm@ornl.gov); [dehartmd@ornl.gov](mailto:dehartmd@ornl.gov); [petrielmjr@ornl.gov](mailto:petrielmjr@ornl.gov)

Presented at the  
*Monte Carlo 2005 Topical Meeting*  
April 17–21, 2005,  
Chattanooga, TN

The submitted manuscript has been authored by a contractor of the U.S. Government under contract No. DE-AC05-00OR22725. Accordingly, the U.S. Government retains a nonexclusive, royalty-free license to publish or reproduce the published form of this contribution, or allow others to do so, for U.S. Government purposes.

# INTEGRATED KENO MONTE CARLO TRANSPORT FOR 3-D DEPLETION WITH SCALE

**Stephen M. Bowman, Mark D. DeHart, and Lester M. Petrie**

Oak Ridge National Laboratory\*

P.O. Box 2008, Oak Ridge, TN 37831-6170

[bowmansm@ornl.gov](mailto:bowmansm@ornl.gov); [dehartmd@ornl.gov](mailto:dehartmd@ornl.gov); [petrielmjr@ornl.gov](mailto:petrielmjr@ornl.gov)

## ABSTRACT

Accurate calculation of the depletion of nuclear materials requires careful determination of the neutron flux density and spectrum in the region(s) of interest. Increasing complexity in reactor designs, evolutionary concepts, and nonreactor applications such as safeguards, security, and nonproliferation, is beginning to require robust geometrical modeling capabilities to capture neutron transport for complex configurations. Monte Carlo transport methods offer the type of flexibility needed for such applications but will present other difficulties not encountered in deterministic transport methods. Two code sequences have been developed at Oak Ridge National Laboratory to perform Monte Carlo-based depletion. Both the KENO V.a and KENO-VI Monte Carlo transport codes in the SCALE (Standardized Computer Analyses for Licensing Evaluation) computer software system have been adapted to work within a depletion code sequence; comparisons with other methods and measured data show excellent agreement.

*Key Words:* KENO, depletion, SCALE, validation

## 1 INTRODUCTION

Accurate calculation of the depletion of nuclear materials requires careful determination of the neutron flux density and spectrum in the region(s) of interest. Increasing complexity in reactor designs, evolutionary concepts, and nonreactor applications such as safeguards, security, and nonproliferation, is beginning to require robust geometrical modeling capabilities to capture neutron transport for complex configurations. Monte Carlo transport methods offer the type of flexibility needed for such applications but will present other difficulties not encountered in deterministic transport methods.

Two code sequences have been developed at Oak Ridge National Laboratory (ORNL) to perform Monte Carlo-based depletion. Both the KENO V.a and KENO-VI Monte Carlo transport codes in the SCALE (Standardized Computer Analyses for Licensing Evaluation) [1] computer software system have been adapted to work within SCALE depletion code sequences. The control modules TRITON and TRITON6 couple the KENO V.a and KENO-VI Monte Carlo codes with the ORIGEN-S depletion code, another functional module in the SCALE system.

The release of SCALE 5 in 2004 included an important new control module named TRITON, which contains a two-dimensional (2-D) depletion sequence employing NEWT and ORIGEN-S. NEWT is a new discrete-ordinates code developed at ORNL that significantly extends the capabilities of discrete-ordinates transport calculations due to its completely arbitrary grid discretization approach. NEWT is used within TRITON to calculate spatial flux

---

\* Managed by UT-Battelle, LLC, for the U.S. Department of Energy under contract no. DE-AC05-00OR22725.

distributions and to collapse nuclide cross sections for use in the ORIGEN-S depletion code. TRITON uses a predictor-corrector method, iteratively calling NEWT and ORIGEN-S to track changing flux and power distributions with burnup and matching time-dependent power to user-specified operating histories.

Despite broad applicability of the 2-D fuel depletion analysis capability of TRITON, there are some domains in which accurate three-dimensional (3-D) depletion capabilities are necessary. For example, criticality analysis for commercial spent fuel in transportation and storage is concerned with the positive reactivity effects of low-burnup fuel near the ends of a fuel assembly, where axial leakage effects, not captured by 2-D methods, may be important. Deterministic transport methods are also unable to perform full-core analysis in a practical sense because of the computational overhead of such large-scale discretization. Additionally, conceptual advanced reactor designs, such as space reactors or Generation IV commercial power reactors, depart from traditional design attributes so that more robust 3-D methods may be required to track fuel depletion or provide reference solutions for 2-D methods. For these reasons, among others, a 3-D depletion capability has been integrated into TRITON, using the 3-D Monte Carlo-based KENO V.a and KENO-VI codes available in SCALE.

## 2 METHODOLOGY

Using Monte Carlo codes for depletion analyses introduces some challenges that must be addressed. Monte Carlo depletion introduces stochastic uncertainty in fluxes. Because the fluxes are used to collapse cross sections, to estimate power distributions, and to deplete the fuel, the predicted number densities contain random uncertainties due to the Monte Carlo solution. Depletion and decay calculations are, by their nature, extrapolations; therefore, errors can be compounded with time.

Minimizing flux errors requires very large numbers of neutron histories. Flux errors will be smallest in the most reactive regions, where the greatest sampling occurs, but will be larger in the lower-power regions. Variance reduction will be important to force significant neutrons out to all regions of interest. Propagation of uncertainties into isotopic concentrations will help in assessing the effect of potentially large flux variances.

The primary advantage of implementing this methodology is applying the strength of Monte Carlo methods for complex 3-D geometries. In addition, KENO V.a performs extremely fast transport calculations relative to other Monte Carlo codes such as MCNP or KENO-VI. Because this methodology is built on the existing TRITON/NEWT (TRITON-2D) methodology in SCALE, direct benchmark comparisons can be made between NEWT and KENO versions of TRITON for validation.

Other capabilities in TRITON provide additional advantages. The use of the one-dimensional (1-D) continuous-energy discrete-ordinates CENTRM with TRITON allows the preparation of multigroup cross sections weighted with a continuous-energy treatment for increased accuracy. TRITON uses ORIGEN-S to perform the depletion/decay calculations. ORIGEN-S underwent significant upgrades in the recent SCALE 5 release, including completely updated nuclear data from ENDF/B-VI, FENDL-2, and EAF-99. Nuclear data were added for hundreds of nuclides that previously were not modeled in any version of ORIGEN. The fission product yield data were increased from 5 fissile nuclides to 30. The methods in ORIGEN-S have also been upgraded to support nontraditional systems. Note that the more widely recognized

ORIGEN-2 code has not been updated in more than 10 years and is no longer supported at ORNL.

A flowchart illustrating the TRITON-KENO depletion sequence is shown in Fig. 1. The specific version of KENO and KMART depends on whether the user selects the KENO V.a or the KENO-VI sequence.

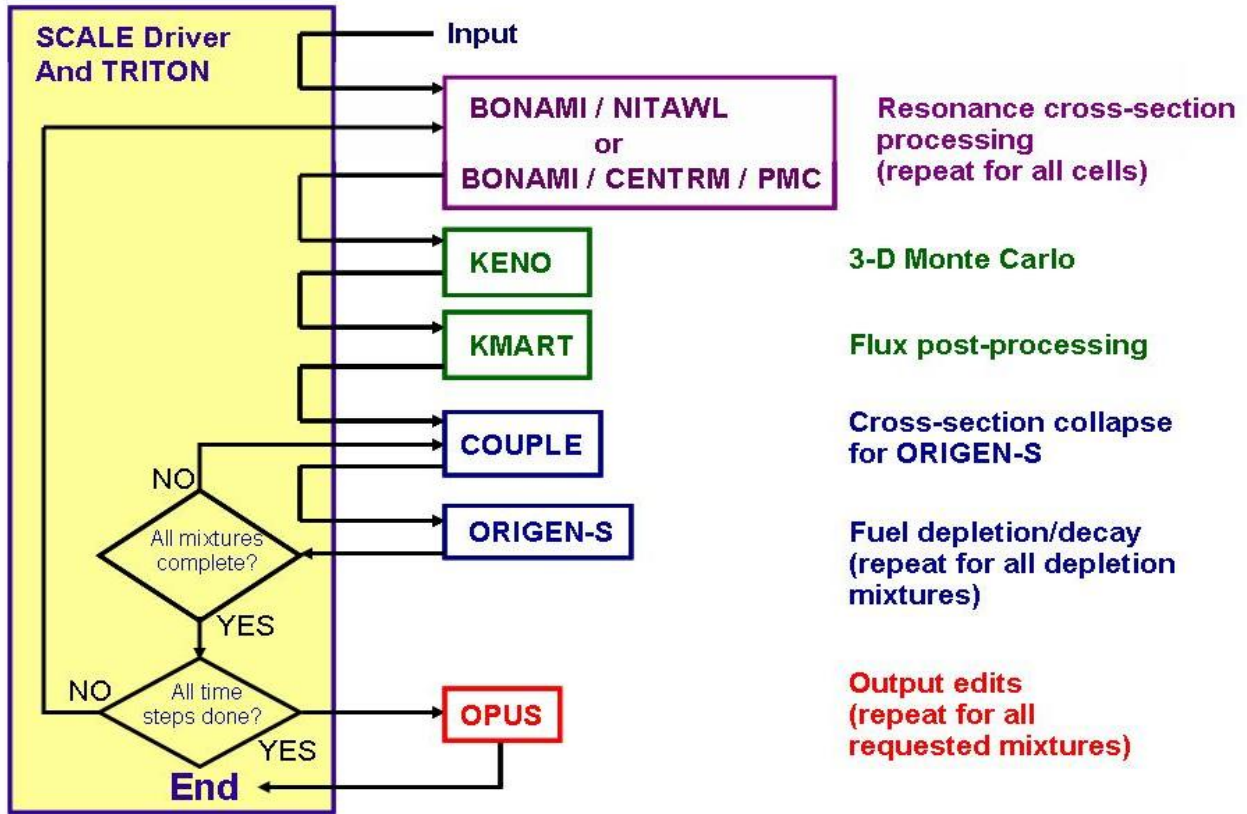

Figure 1. TRITON-KENO depletion sequence.

For both transport codes, the SCALE utility codes KMART and KMART6, originally developed to post-process KENO calculations, have been adapted to provide collapsed cross sections and fluxes required by TRITON for setting up ORIGEN-S depletion calculations. Restart capabilities of the KENO codes have been used to provide an improved starting source for each depletion step, further improving calculation times. Ongoing work seeks to study and implement methods using variance reduction techniques to improve the efficacy of iterative depletion based on Monte Carlo transport solutions. Error propagation from the results of Monte Carlo simulations is planned as a key attribute of this system.

### 3 RESULTS

Benchmark calculations have been performed using pressurized water reactor (PWR) fuel assembly data provided in validation reports of the 1-D SAS2/XSDRNPM depletion sequence in SCALE. Benchmark models of the spent fuel assemblies have been developed with both TRITON/KENO V.a (TRITON-K5) and TRITON6/KENO-VI (TRITON-K6). Results have been compared with the measured radiochemical spent fuel assay data given in the reports and previously calculated SAS2 and TRITON-2D results. Benchmark calculations have been performed for fuel assemblies from the following four PWRs:

- Calvert Cliffs
- Obrigheim
- San Onofre
- Trino Vercelles

Note that these validation cases are standard benchmarks. The intent in using these cases is to ensure that the Monte Carlo codes have been properly incorporated into the TRITON depletion methodology. These cases are not applications that specifically require the Monte Carlo methods to obtain accurate results.

#### 3.1 Calvert Cliffs 14 × 14 Fuel

The Calvert Cliffs fuel assembly is a combustion engineering 14 × 14 fuel assembly design. The fuel assembly modeled was D047. The specific location in the assembly of the measured sample was rod MKP109, at an elevation of 165.22 cm with a burnup of 44.34 GWd/MTU [2]. Measured data were obtained for the major actinides, cesium isotopes, and other fission products of importance to burnup credit (i.e., strong neutron absorbers). Of the assemblies modeled in this project, this one had the most nuclides that were measured. A comparison of the calculated results from SAS2, TRITON-2D, TRITON-K5, and TRITON-K6 with the measured data is presented in Table I and Figs. 2 (actinides) and 3 (fission products).

These results demonstrate consistency between the 1-D, 2-D, and 3-D SCALE depletion sequences. The comparisons with the measured data show calculational errors of generally 10% or less for the actinides and most fission products. Results for six of the fission products deviate from the measured data by approximately 20%. Only the discrepancies in the  $^{149}\text{Sm}$  and  $^{151}\text{Sm}$  values exceed this amount.

**Table I. Calvert Cliffs fuel assembly D047, rod MKP109  
(44.34 GWd/MTU)**

Nuclide(s)	Measured (g/g UO <sub>2</sub> )	SAS2 % Diff.	TRITON/ NEWT % Diff.	TRITON/ KENO V.a % Diff.	TRITON6/ KENO-VI % Diff.
U-234	1.20E-04	1.40	1.14	1.16	1.14
U-235	3.54E-03	-8.70	-5.05	-5.44	-5.40
U-236	3.69E-03	1.90	-1.81	1.81	1.80
U-238	8.25E-01	-0.10	-0.16	-0.16	-0.18
Pu-238	2.69E-04	-5.00	-6.63	-6.56	-6.59
Pu-239	4.36E-03	-1.50	6.26	4.96	5.00
Pu-240	2.54E-03	-3.90	-0.17	-0.70	-0.96
Pu-241	1.02E-03	-2.40	-0.71	-1.30	-1.14
Pu-242	8.40E-04	4.10	-0.90	-0.65	-0.49
Np-237	4.68E-04	7.20	7.25	7.13	7.25
Cs-133	1.24E-03	3.40	3.47	3.47	3.46
Cs-134	3.00E-05	-18.60	-19.45	-19.45	-19.43
Cs-135	4.30E-04	1.70	3.42	3.20	3.22
Cs-137	1.25E-03	1.20	-0.40	-0.40	-0.41
Nd-143	7.63E-04	0.50	1.63	1.47	1.48
Nd-144	1.64E-03	0.20	-0.07	0.03	0.02
Nd-145	7.44E-04	-0.60	-0.39	-0.34	-0.31
Nd-146	8.30E-04	1.30	1.74	1.74	1.72
Nd-148	4.28E-04	0.30	0.60	0.64	0.61
Nd-150	2.08E-04	4.20	4.71	4.71	4.68
Pm-147 + Sm-147	2.68E-04	-4.80	-5.88	-5.80	-5.76
Sm-148	2.22E-04	-18.20	-17.98	-17.98	-17.99
Sm-149	4.70E-06	-49.10	-51.18	-51.55	-51.39
Sm-150	3.61E-04	-5.60	-6.03	-6.03	-5.99
Sm-151 + Eu-151	9.78E-06	38.50	N/A	35.18	34.62
Sm-152	1.21E-04	22.00	20.99	20.68	20.89
Eu-153	1.48E-04	2.50	0.54	0.79	0.75
Sm-154 + Eu-154 + Gd-154	8.42E-05	-3.40	-3.73	-3.94	-4.01
Eu-155 + Gd-155	9.82E-06	-25.30	-23.96	-24.16	-24.17

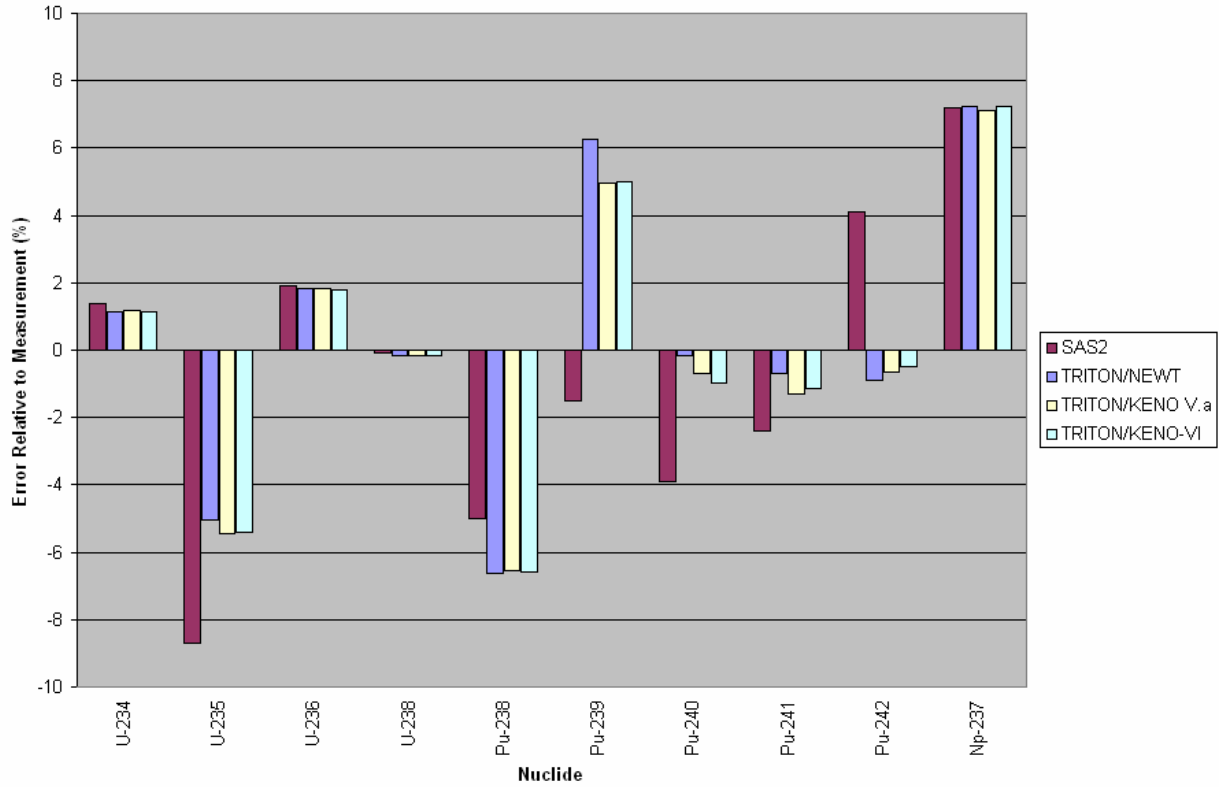

Figure 2. Calvert Cliffs actinide calculated results vs measured data.

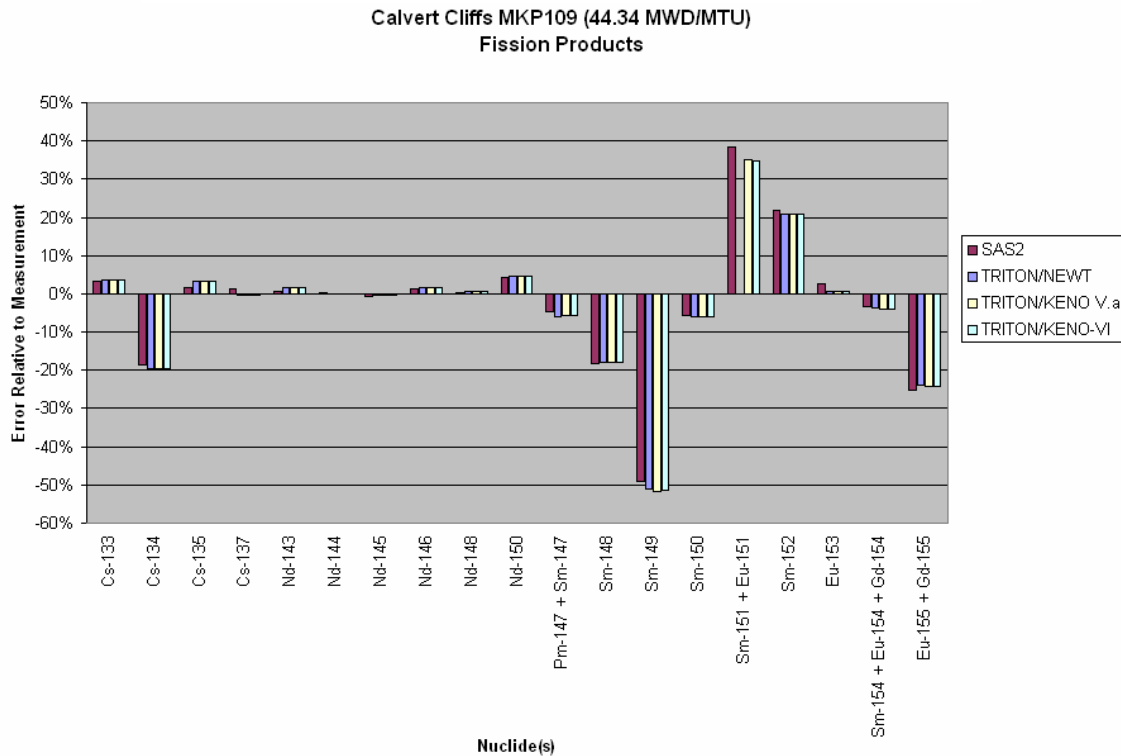

Figure 3. Calvert Cliffs fission product calculated results vs measured data.

### 3.2 Obrigheim

Isotopic measurements of the Obrigheim German PWR  $14 \times 14$  assemblies were performed in Europe. For these measurements, each assembly was cut in half lengthwise and dissolved. The radiochemical analysis for a number of actinide and fission products was subsequently carried out by four independent institutes. The Obrigheim measurements thus provide "assembly-average" isotopic values that, in comparison with individual pellet measurements, are more consistent with the spatially independent (i.e., assembly-average) point-depletion techniques typically used to characterize spent fuel for away-from-reactor applications.

The assembly modeled as part of this initial validation of TRITON and KENO was assembly 176, batch 90, with an enrichment of 3.1 wt % and a burnup of 29.52 GWd/MTU. The comparison of results in Table II shows good agreement between measurements and calculations, except for  $^{242}\text{Cm}$ , one of the lesser important actinides.

**Table II. Obrigheim fuel assembly 176  
(29.52 GWd/MTU)**

Nuclide	Measured (mg/g U)	SAS2 % Diff.	TRITON/ NEWT % Diff.	TRITON/ KENO V.a % Diff.	TRITON/ KENO-VI % Diff.
U-235	9,180.00	-2.0	-2.0	-0.2	-0.3
U-236	3,810.00	1.2	0.7	0.2	0.3
Pu-238	107.1	3.0	-2.2	-2.6	-2.5
Pu-239	4,943.00	< 0.1	-0.2	1.1	1.1
Pu-240	2,040.00	-0.1	1.1	1.0	0.9
Pu-241	1,128.00	0.5	-0.9	-0.4	-0.4
Pu-242	438	-4.7	-8.1	-9.3	-9.2
Cm-242	21.8	-23.1	-27.1	-27.3	-27.2
Cm-244	19.2	-9.1	-9.9	-11.6	-11.2

### 3.3 San Onofre Mixed Oxide (MOX) Fuel

The EEI-Westinghouse Plutonium Recycle Demonstration Program, sponsored by Edison Electric Institute, Westinghouse Electric Corporation, and the Atomic Energy Commission, was conducted between 1968 and 1974. A significant part of the program involved the measurement of isotopic compositions of uranium, plutonium, and a few other actinides in depleted MOX fuel withdrawn from the San Onofre PWR Unit 1, a reactor having a Westinghouse design and operated by Southern California Edison and San Diego Gas & Electric companies. Four MOX fuel assemblies were loaded at the start of cycle 2 of the San Onofre Nuclear Generation Station Unit 1 and irradiated during both cycles 2 and 3. Isotopic composition analyses were conducted by Westinghouse Electric Corporation on six sample pellets from four fuel rods of the MOX test assembly D51X. The measured actinide inventories have been used to benchmark the use of SCALE/SAS2H depletion calculations for MOX fuel [3].



As part of the current validation, the sample pellet from pin 079, at an elevation of 49 inches with a burnup of 20.89 GWd/MTU, was modeled. Comparisons of the calculated results from SAS2, TRITON-K5, and TRITON-K6 with the measured data are presented in Table III. A TRITON-2D model was not available for comparison. Once again, the calculated results are consistent and generally agree well with the measured data. The two nuclides with poor results,  $^{234}\text{U}$  and  $^{238}\text{Pu}$ , have relatively low concentrations and importance.

**Table III. San Onofre MOX fuel assembly DX51, pin 079  
(20.89 GWd/MTU)**

Nuclide	Measured	SAS2 % Diff.	TRITON/ KENO V.a % Diff.	TRITON/ KENO-VI % Diff.
U-234	4.66E-02	-13.1	-13.3	-13.8
U-235	4.40E+00	-2.0	1.1	1.0
U-236	4.89E-01	6.6	2.5	2.5
U-238	9.43E+02	0.0	0.0	0.0
Pu-238	2.82E-01	-36.3	-35.1	-35.2
Pu-239	1.65E+01	5.2	3.8	3.9
Pu-240	7.68E+00	-3.3	1.8	2.5
Pu-241	3.66E+00	1.5	1.7	0.8
Pu-242	8.97E-01	5.9	3.3	3.3
Nd-148	2.27E-01	0.1	0.6	0.6

### 3.4 TrinoVercelles

Trino Vercelles is an 825-MW Westinghouse PWR located in Italy. Based on one of the earlier Westinghouse designs, this reactor is unlike most PWR designs in the United States; however, it is similar to that of the Yankee Rowe PWR. Use of this uncommon design will serve to demonstrate the modeling capabilities of KENO for nonuniform fuel assembly designs. The fuel assembly design is based on a  $15 \times 15$  lattice of fuel pins with 16 of the outer pins excluded to accommodate cruciform positions. The KENO model consists of a cluster of four assemblies, as illustrated in the 2-D plot in Fig. 4, with periodic boundary conditions.

Radiochemical assay data obtained from assembly 509-069, irradiated during both the first and second fuel cycles, were used for benchmarking in this validation [4]. The yellow circle in Fig. 4 represents fuel rod E11, which is the location of the measured assay data used in this benchmark. Comparisons of the calculated results from SAS2, TRITON-K5, and TRITON-K6 with the measured data are presented in Table IV. A TRITON-2D model was not available for comparison. Once again, the calculated results are consistent and generally agree well with the measured data, except for  $^{134}\text{Cs}$  and  $^{154}\text{Eu}$ . The TRITON results are generally better than the SAS2 results.

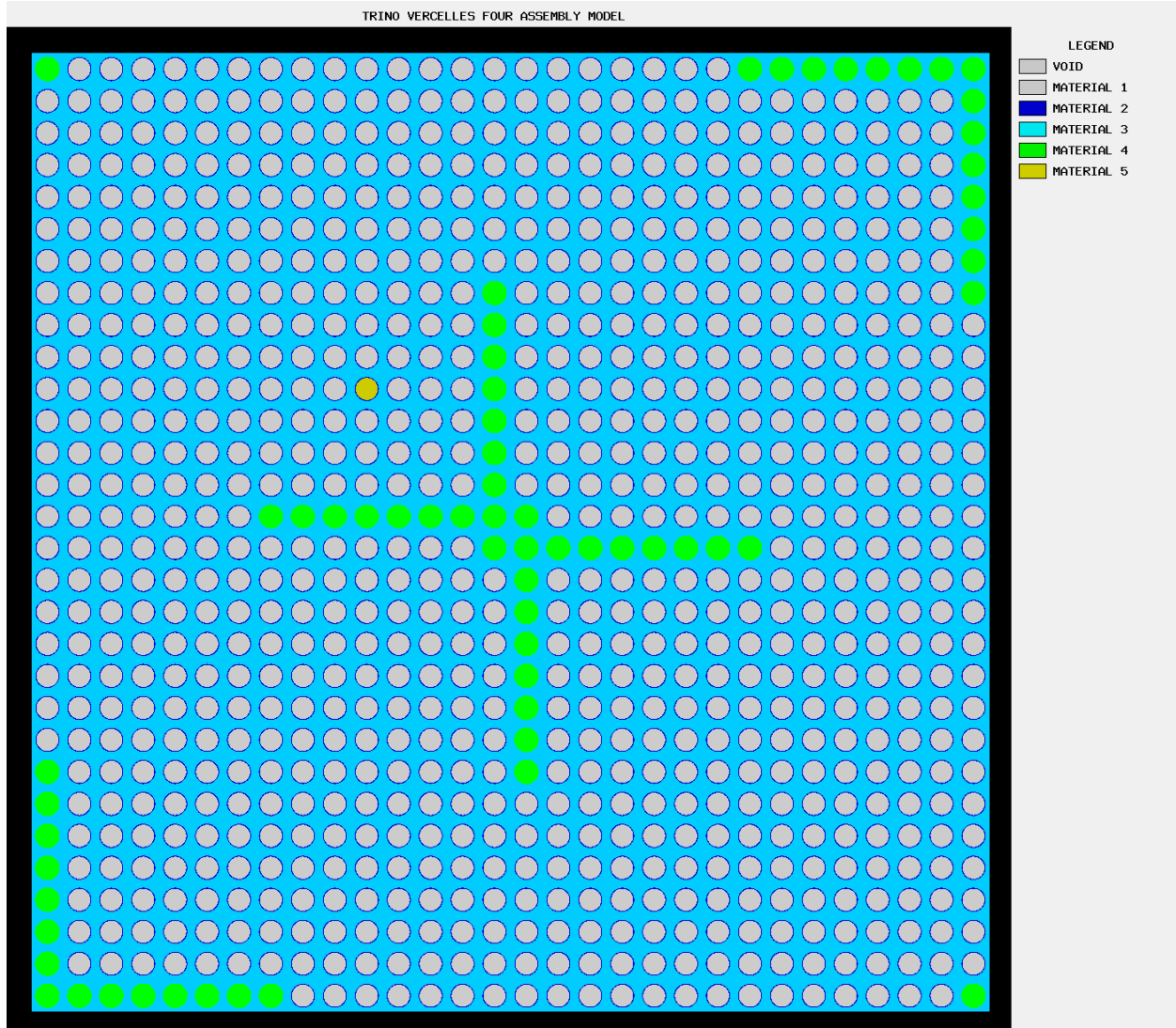

Figure 4. 2-D plot of KENO V.a model for Trino Vercelles assembly 509-069.

**Table IV. Trino Vercelles fuel assembly 509-069, Rod E11  
(12.859 GWd/MTU)**

Nuclide	Measured (mg/g U)	SAS2 % Diff.	TRITON/ KENO V.a % Diff.	TRITON/ KENO-VI % Diff.
U-235	1.95E+01	0.51	-0.11	-0.21
U-236	2.45E+00	-5.75	-5.35	-5.10
U-238	9.59E+02	-0.05	-0.06	0.00
Pu-239	4.58E+00	-1.51	1.38	1.07
Pu-240	8.40E-01	8.20	6.60	4.59
Pu-241	4.00E-01	3.62	-0.38	3.54
Pu-242	4.60E-02	10.26	3.91	6.59
	(curies/g U)			
Cs-134	2.49E-02	-25.94	-24.41	-24.39
Cs-137	3.94E-02	0.71	-0.59	-0.42
Eu-154	1.37E-03	-25.62	-23.50	-23.26

### 3.5 Summary of Results

A composite plot of the results for all four PWR fuel assembly depletion models is shown in Fig. 5. Only the TRITON-K5 results are shown because the TRITON-K6 results are statistically identical. The calculated results for all major actinides and most fission products are within 10% of the measured data. Nuclides with discrepancies of greater than 20% include  $^{238}\text{Pu}$ ,  $^{242}\text{Cm}$ ,  $^{134}\text{Cs}$ ,  $^{149}\text{Sm}$ ,  $^{151}\text{Sm}$ ,  $^{154}\text{Eu}$ ,  $^{155}\text{Eu}$ , and  $^{155}\text{Gd}$ .

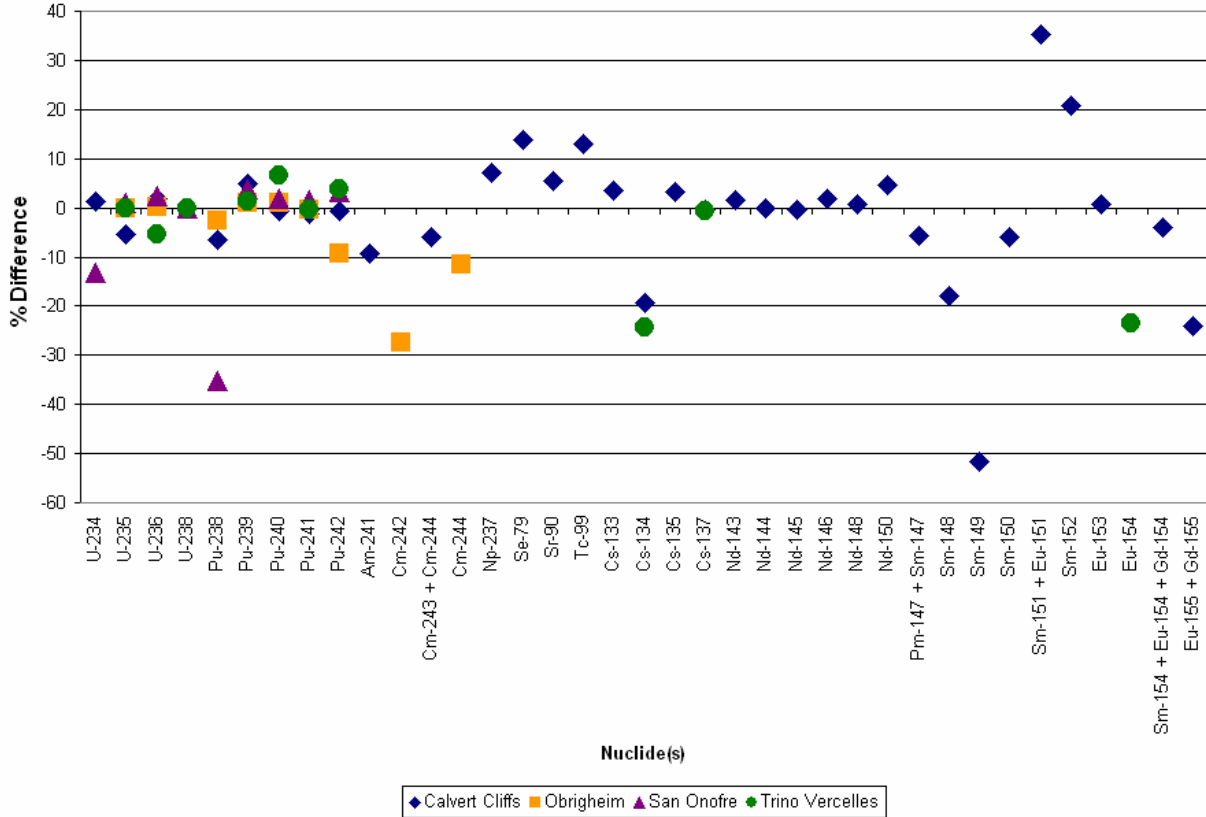

Figure 5. Comparison of TRITON/KENO results with all measured data.

## 4 CONCLUSIONS

The updated TRITON and TRITON6 depletion sequences using the 3-D Monte Carlo codes KENO V.a and KENO-VI, respectively, show tremendous potential for application in 3-D configurations. Performance of both depletion sequences has been assessed by comparison with 2-D results obtained using deterministic transport method, and by direct comparison to measured spent fuel data. Results show excellent agreement with other codes and data. These calculation sequences provide simple and straightforward analysis capabilities for a wide variety of applications. Planned future work includes implementation of variance reduction techniques to improve computational efficiency and statistical uncertainty propagation from the Monte Carlo calculations to the predicted isotopic concentrations.

## 5 ACKNOWLEDGMENTS

This research was sponsored by the Laboratory Directed Research and Development Program of Oak Ridge National Laboratory, managed by UT-Battelle, LLC, for the U.S. Department of Energy under contract no. DE-AC05-00OR22725.

## 6 REFERENCES

1. *SCALE: A Modular Code System for Performing Standardized Computer Analyses for Licensing Evaluations*, NUREG/CR-0200, Rev. 7 (ORNL/NUREG/CSD-2/R7), Vols. I, II, and III, June 2004 (DRAFT). Available from Radiation Safety Information Computational Center at Oak Ridge National Laboratory as CCC-725.
2. O. W. Hermann, S. M. Bowman, M. C. Brady, and C. V. Parks, *Validation of the SCALE System for PWR Spent Fuel Isotopic Composition Analyses*, ORNL/TM-12667, Lockheed Martin Energy Research Corp., Oak Ridge National Laboratory, 1995.
3. O. W. Hermann, *Benchmark of SCALE (SAS2H) Isotopic Predictions of Depletion Analyses for San Onofre PWR MOX Fuel*, ORNL/TM-1999/326, Lockheed Martin Energy Research Corp., Oak Ridge National Laboratory, 2000.
4. M. D. DeHart and O. W. Hermann, *An Extension of the Validation of SCALE (SAS2H) Isotopic Predictions for PWR Spent Fuel*, ORNL/TM-13317, Lockheed Martin Energy Research Corp., Oak Ridge National Laboratory, 1996.